

ELECTRIC TOOL PARTS LIST

■ DISC GRINDER
Model G 23SF

2002-6-1
(E3-1)

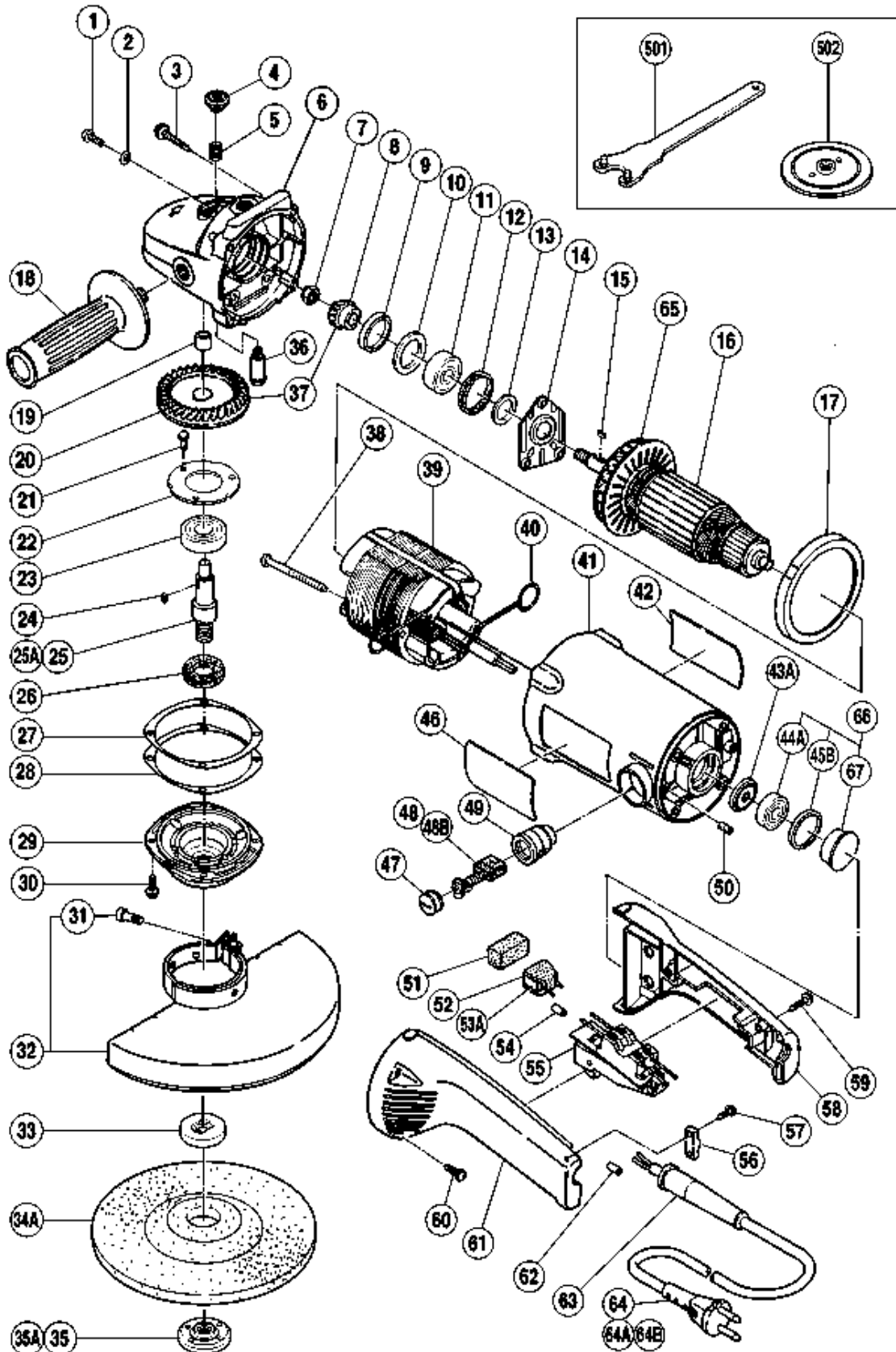

PARTS

G23SF

ITEM No.	CODE No.	DESCRIPTION	No. USED	REMARKS
1	949-238	MACHINE SCREW M5X14 (10 PCS.)	3	
2	949-454	SPRING WASHER M5 (10 PCS.)	3	
3	301-654	TAPPING SCREW (W/FLANGE) D5X35	4	
4	306-888	PUSHING BUTTON	1	
5	306-889	SPRING	1	
6	306-105	GEAR COVER ASS'Y	1	INCLUD.4,5,19,36
7	946-228	U-NUT M8	1	
8	306-110	PINION	1	
9	306-107	SEAL RING (A)	1	
10	306-113	WASHER (A)	1	
11	630-1DD	BALL BEARING 6301DDCMPS2L	1	
12	994-208	RUBBER RING (B)	1	
13	990-864	FELT PACKING (A)	1	
14	306-106	BEARING COVER	1	
15	940-533	FEATHER KEY 3X3X10	1	
* 16	360-288C	ARMATURE 110V	1	INCLUD.65
* 16	360-288E	ARMATURE 220V-240V	1	INCLUD.65
17	306-103	FAN GUIDE	1	
18	937-981	SIDE HANDLE FOR M14	1	
19	673-002	NEEDLE BEARING (HK1212)	1	
20	306-109	GEAR	1	
21	992-038	SEAL LOCK SCREW (W/SP. WASHER) M5X10	3	
22	937-035	BEARING COVER (B)	1	
23	630-2DD	BALL BEARING 6302DDCMPS2L	1	
24	980-809	FEATHER KEY 4X4X8	1	
* 25	990-857	SPINDLE	1	
* 25A	994-218	SPINDLE ASS'Y	1	INCLUD.35A FOR THA
26	990-852	FELT PACKING (B)	1	
27	306-112	SEAL PLATE	1	
28	306-981	THRUST WASHER	1	
29	306-111	PACKING GLAND	1	
30	994-192	HEX. SOCKET HD. BOLT (W/FLANGE) M5X16	4	
31	306-887	BOLT M8X22	1	
32	306-120	WHEEL GUARD ASS'Y	1	INCLUD.31
* 33	937-907Z	WHEEL WASHER (A)	1	
* 33	937-928Z	WHEEL WASHER (A) FOR D16 HOLE	1	FOR THA
* 33	937-908Z	WHEEL WASHER (B)	1	FOR AUS,NZL
* 34A	316-825	D. C. WHEELS 230MM A24R (25 PCS.)	1	FOR NZL,AUS,SAF,GRE,ITA,SYR,SAU,THA,KUW
* 35	937-909Z	WHEEL NUT M14X2	1	
* 35	937-929Z	WHEEL NUT M16X1.5	1	TILL 12.1993 FOR THA
* 35A	994-155	WHEEL NUT M16X2	1	SINCE 1.1994 FOR THA

*:ALTERNATIVE PARTS

PARTS

G23SF

ITEM No.	CODE No.	DESCRIPTION	No. USED	REMARKS
36	306-890	LOCK PIN	1	
37	306-108	GEAR AND PINION ASS'Y	1	INCLUD.8,20
38	961-501	HEX. HD. TAPPING SCREW D5X60	2	
* 39	340-263C	STATOR ASS'Y 110V	1	INCLUD.40
* 39	340-262E	STATOR ASS'Y 220V-230V	1	INCLUD.40
* 39	340-262F	STATOR ASS'Y 240V	1	INCLUD.40
* 39	340-262G	STATOR ASS'Y 220V-230V	1	INCLUD.40 FOR NZL,SAF,ITA,FRG,FRA,HOL,
*				DEN,FIN,SWE,NOR,ESP
* 39	340-262H	STATOR ASS'Y 240V	1	INCLUD.40 FOR GBR
* 39	340-263G	STATOR ASS'Y 110V	1	INCLUD.40 FOR GBR
40	958-032	BRUSH TERMINAL	2	
41	306-812	HOUSING ASS'Y	1	INCLUD.49,50
* 42		NAME PLATE	1	
43A	310-998	DUST SEAL	1	
44A	600-0VV	BALL BEARING 6000VVCMP2L	1	
45B	994-202	RUBBER RING (A)	1	
* 46		HITACHI LABEL	1	
47	940-540	BRUSH CAP	2	
* 48	999-044	CARBON BRUSH (1 PAIR)	2	
* 48B	999-074	CARBON BRUSH (AUTO STOP TYPE) (1 PAIR)	2	FOR ESP,SAF
49	980-487	BRUSH HOLDER	2	
50	938-477	HEX. SOCKET SET SCREW M5X8	2	
51	306-117	DUST PACKING	1	
* 52	306-114	SUPPORT (B)	1	FOR NOISE SUPPRESSOR
* 53A	930-039	NOISE SUPPRESSOR	1	FOR NZL,GBR,SAF,ITA,FRG,FRA,HOL,DEN,FIN,
*				SWE,NOR,ESP
* 54	961-820	TUBE (D)	2	FOR NOISE SUPPRESSOR
* 55	306-116	SWITCH (2P PILLAR TYPE) W/SAFETY LOCK	1	W/LOCK
* 55	306-115	SWITCH (2P PILLAR TYPE) W/SAFETY LOCK	1	W/O LOCK FOR AUS,GBR,ITA,FRA,FIN,NOR,NZL
56	960-266	CORD CLIP	1	
57	984-750	TAPPING SCREW (W/FLANGE) D4X16	2	
58	306-119	HANDLE (B)	1	
59	304-035	TAPPING SCREW (W/FLANGE) D4X25 (BLACK)	2	
60	305-558	TAPPING SCREW (W/FLANGE) D5X25 (BLACK)	4	
61	306-118	HANDLE (A)	1	
* 62	981-373	TUBE (D)	2	FOR CORD
* 63	958-049	CORD ARMOR D8.2	1	
* 63	940-778	CORD ARMOR D10.7	1	
* 64	500-214Z	CORD	1	(CORD ARMOR D10.7)
* 64	500-247Z	CORD	1	(CORD ARMOR D10.7) FOR ITA FRG,FRA,HOL,
*				DEN,FIN,SWE,NOR,ESP

PARTS

G23SF

ITEM No.	CODE No.	DESCRIPTION	No. USED	REMARKS
* 64	500-234Z	CORD	1	(CORD ARMOR D8.2) FOR GRE
* 64	500-423Z	CORD	1	(CORD ARMOR D8.2) FOR SAU,KUW
* 64	500-439Z	CORD	1	(CORD ARMOR D10.7) FOR AUS,NZL
* 64	500-246Z	CORD	1	(CORD ARMOR D10.7) FOR GBR
* 64	500-245Z	CORD	1	(CORD ARMOR D10.7) FOR SYR
* 64A	500-438Z	CORD	1	(CORD ARMOR D10.7) FOR SAF
* 64B	500-435Z	CORD	1	(CORD ARMOR D8.2) FOR HKG
65	319-657	FAN	1	
66	320-246	BUSHING AND BALL BEARING ASS'Y	1	INCLUD.44A,45B,67
67	320-247	BEARING BUSHING	1	

STANDARD ACCESSORIES

ITEM No.	CODE No.	DESCRIPTION	No. USED	REMARKS
501	937-913Z	WRENCH	1	
* 502	937-917Z	WHEEL NUT (B)	1	(DIAMOND WHEEL) FOR AUS,NZL