

Service Manual

Cordless Drill & Driver

EY6406 • EY6407 • EY6431

CONTENTS

	Page
· Specifications	1
· Disassembly / Assembly Instructions	4
· Wiring Connection Diagram	5
· Troubleshooting Guide	6
· Schematic Diagram	7
· Exploded View & Replacement Parts List	8-11

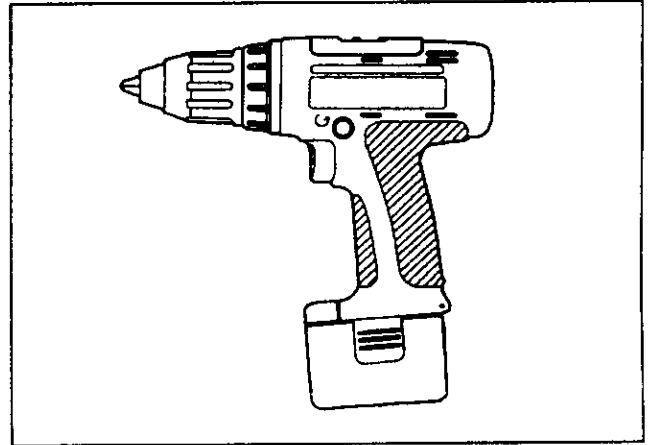

SPECIFICATIONS

MAIN UNIT

Model	EY6406		EY6407	EY6431
Motor	DC Motor 12V			DC Motor 15.6V
No load speed	LOW	400/min (rpm.)		450/min (rpm.)
	HIGH	1300/min (rpm.)		1100/min (rpm.)
Chuck capacity	ϕ 0.5 ~ ϕ 10mm (1/32" ~ 3/8")		ϕ 1.0 ~ ϕ 13mm (1/16" ~ 1/2")	
Maximum torque	LOW	22.5Nm (230kgf-cm, 199in-lbs.)		31.9Nm (325kgf-cm, 282in-lbs.)
	HIGH	6.3Nm (65kgf-cm, 56in-lbs.)		8.8Nm (90kgf-cm, 78in-lbs.)
Clutch torque	Approx. 1.0Nm (10kgf-cm, 8.7in-lbs.) - 5.4Nm (55kgf-cm, 47.7in-lbs.)			Approx. 1.0Nm (10kgf-cm, 8.7in-lbs.) - 6.9Nm (70kgf-cm, 61in-lbs.)
Overall length	202mm (7-61/64")		208mm (8-3/16")	
Weight (with battery pack)	1.7kg (3.74lbs.) with EY9106		1.8kg (3.96lbs.) with EY9200	2.0kg (4.4lbs.) with EY9230/EY9136

BATTERY PACK

	EY9106	EY9108	EY9200	EY9230	EY9136
Storage battery	Ni-Cd battery	Ni-MH battery			Ni-Cd battery
Battery voltage	12V DC (1.2V X 10 cells)			15.6V DC (1.2V X 13 cells)	

BATTERY CHARGER

Weight	0.78kg (1.72lbs.)	
Charging time	Approx. 30min. with EY9106/9108/9136	45min. with EY9200/9230

Panasonic

©1999 Matsushita Electric Works, Ltd.
All rights reserved. Unauthorized copying
and distribution is a violation of law.

⚠WARNING

This service literature is designed for experienced repair technicians only and is not designed for use by the general public. It does not contain warnings or cautions to advise non-technical individuals of potential dangers in attempting to service a product. Products powered by electricity should be serviced or repaired only by experienced professional technicians. Any attempt to service or repair the product or products dealt with in this service information by anyone else could result in serious injury or death.

DISASSEMBLY / ASSEMBLY INSTRUCTIONS

Ref. No. 1A	Procedure 1A	Removal of the keyless drill chuck.
-------------	--------------	-------------------------------------

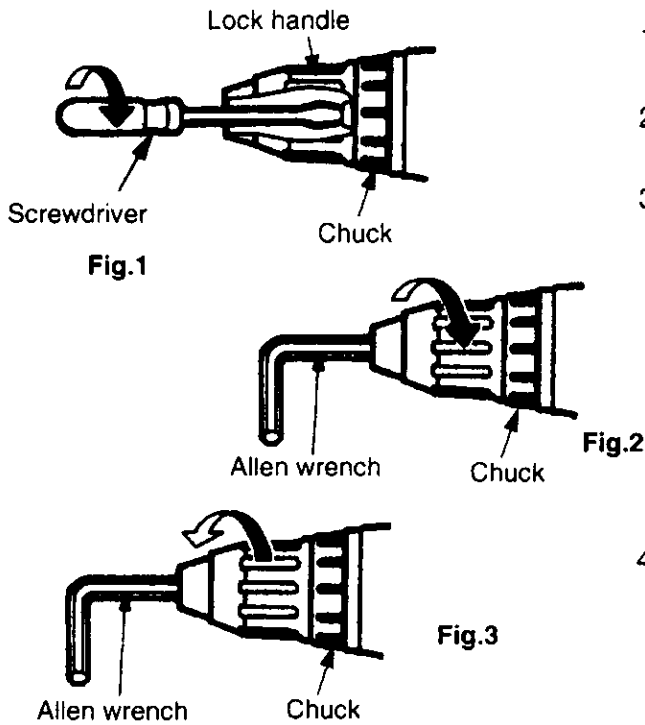

1. Set the clutch handle to position  and "LOW" position.
2. Turn the lock handle counterclockwise direction to open the chuck jaws.
3. Use a screwdriver to turn the chuck fastening screw inside the chuck clockwise direction of the arrow, and remove the screw. (See Fig. 1)
NOTE : If the chuck fastening screw will not come loose, insert the allen wrench into the chuck and lightly tap in the clockwise direction with a hammer to tighten the chuck, and then loosen the chuck fastening screw. (See Fig.2)
4. Insert the allen wrench into the chuck, and turn counterclockwise direction in the arrow with holding the unit by the vise to remove the chuck. (See Fig. 3)

Ref. No. 2A	Procedure 2A	Removal of the housings.
-------------	--------------	--------------------------

<EY6406•6407>

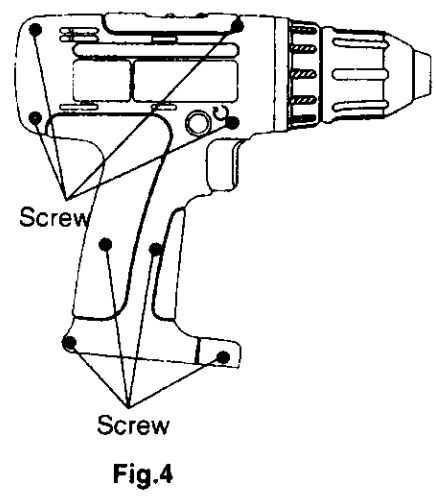

1. Remove 8 housing screws. (See Fig.4-5)

<EY6431>

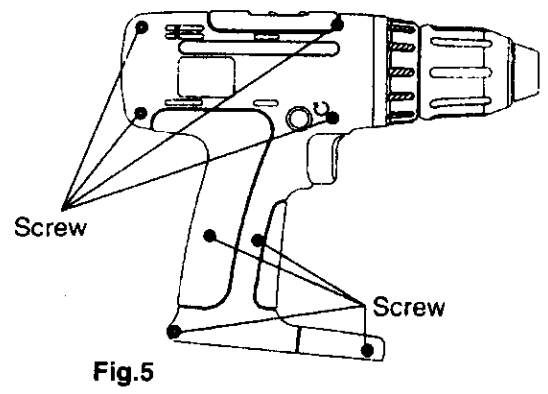

Ref. No. 2B	Procedure 2A→2B	Removal or attachment of the motor.
-------------	-----------------	-------------------------------------

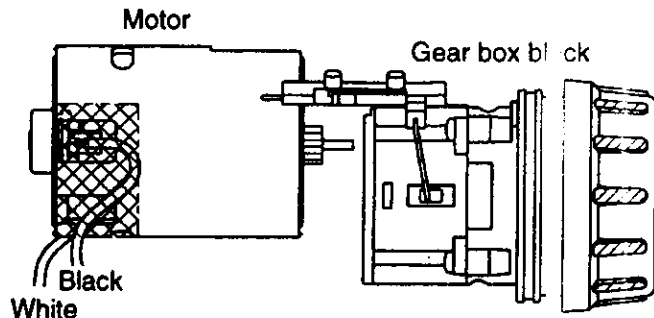

Fig.6

(Removal of the motor.)

1. Remove the motor with the gear box block from housing.
2. Separate the motor from the gear box block by twisting the motor to unlock tabs.

(Attachment for the motor.)

3. Motor mounting base and the positioning rib of gear case should be set. (See Fig. 6)

Ref. No. 2C	Procedure 2A→2B→C	Removal or attachment of the gear box block.
-------------	-------------------	--

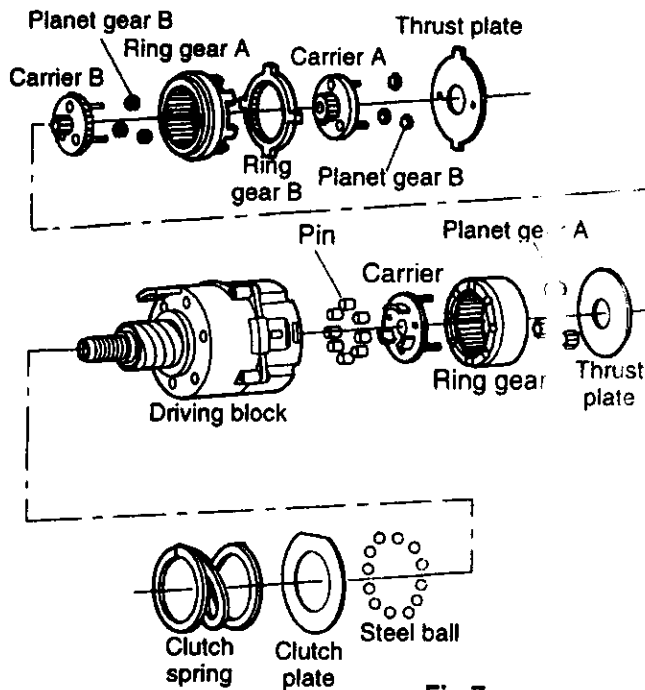

Fig.7

(Removal of the gear box block.)

1. Turn the thrust plate to remove.
2. The internal parts of gear box block can be removed one after another.(See Fig. 7)

(Attachment for the gear box block.)

3. If the lock ring comes out, reassemble in the correct direction. (See Fig.8)
4. Start from inserting 6 pins into the driving block as shown in the Fig. 9.
5. Assemble the other parts in reverse order as shown in the Fig. 7.

NOTE : Carrier, Carrier A and B, Ring gear, and Ring gear A have their own correct directions for proper reassembly.

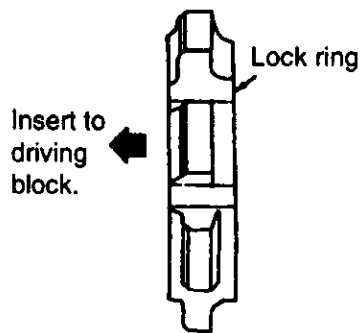

Fig.8

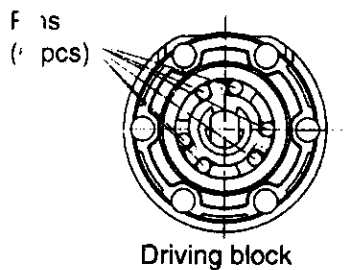
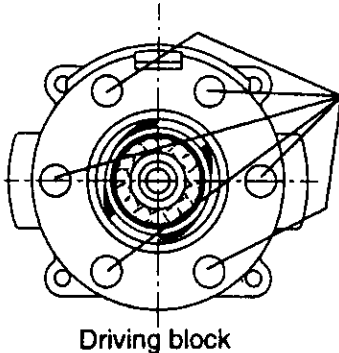
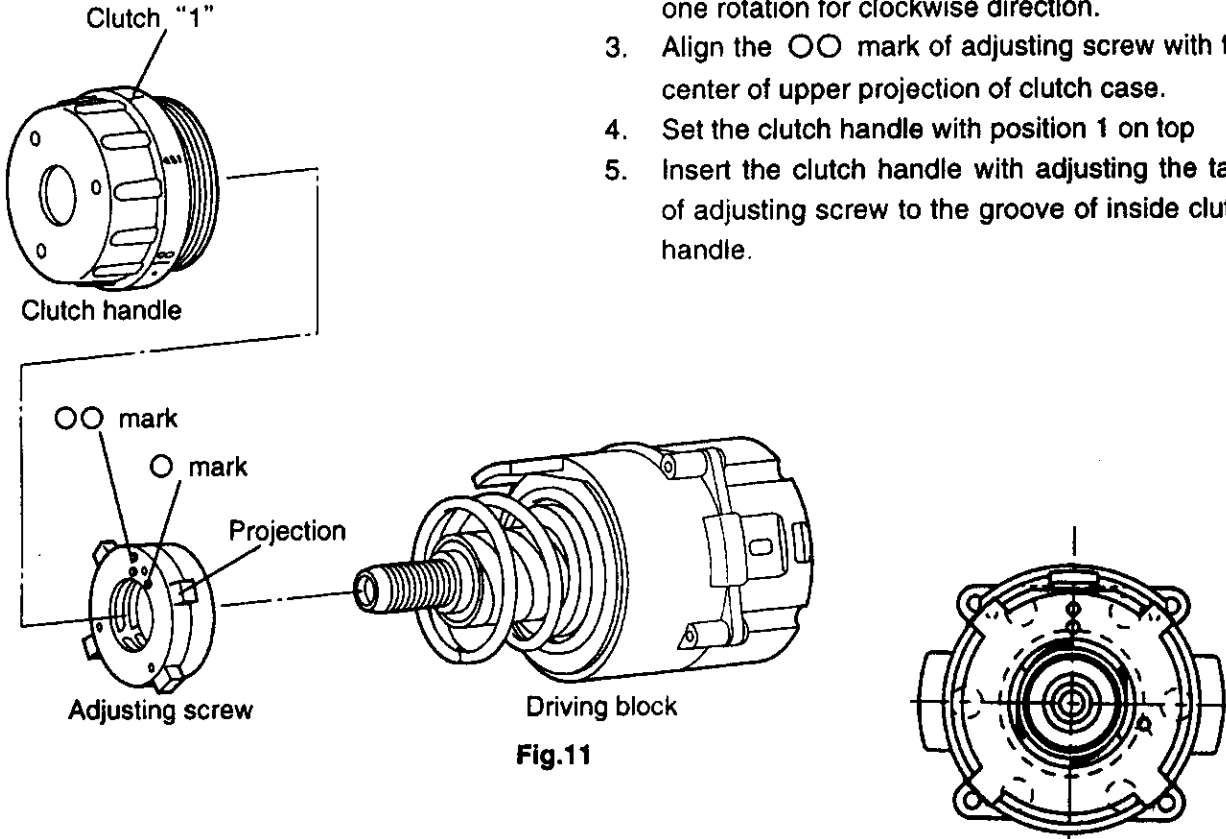

Fig.9

Ref. No. 2D	Procedure 2A→2B→2C→2D	Attachment for steel balls.
 <p data-bbox="527 321 755 383">Steel balls (2 pcs × 6 holes)</p> <p data-bbox="243 559 406 590">Driving block</p> <p data-bbox="284 621 365 652">Fig.10</p>		<ol style="list-style-type: none"> 1. Reinstalling place 2pcs of steel balls into each of the 6 holes. (See Fig. 10)

Ref. No. 2E	Procedure 2A→2B→2C→2D→2E	Attachment for the adjusting screw and the clutch handle.
 <p data-bbox="267 963 397 994">Clutch "1"</p> <p data-bbox="203 1253 365 1284">Clutch handle</p> <p data-bbox="235 1357 365 1388">OO mark</p> <p data-bbox="332 1408 430 1440">O mark</p> <p data-bbox="414 1471 535 1502">Projection</p> <p data-bbox="251 1647 446 1678">Adjusting screw</p> <p data-bbox="714 1647 868 1678">Driving block</p> <p data-bbox="706 1699 787 1730">Fig.11</p>		<ol style="list-style-type: none"> 1. Align the O mark of adjusting screw with the center of upper projection of clutch case. 2. Turn the adjusting screw into driving block about one rotation for clockwise direction. 3. Align the OO mark of adjusting screw with the center of upper projection of clutch case. 4. Set the clutch handle with position 1 on top 5. Insert the clutch handle with adjusting the tabs of adjusting screw to the groove of inside clutch handle.

WIRING CONNECTION DIAGRAM

■ EY6406/EY6407

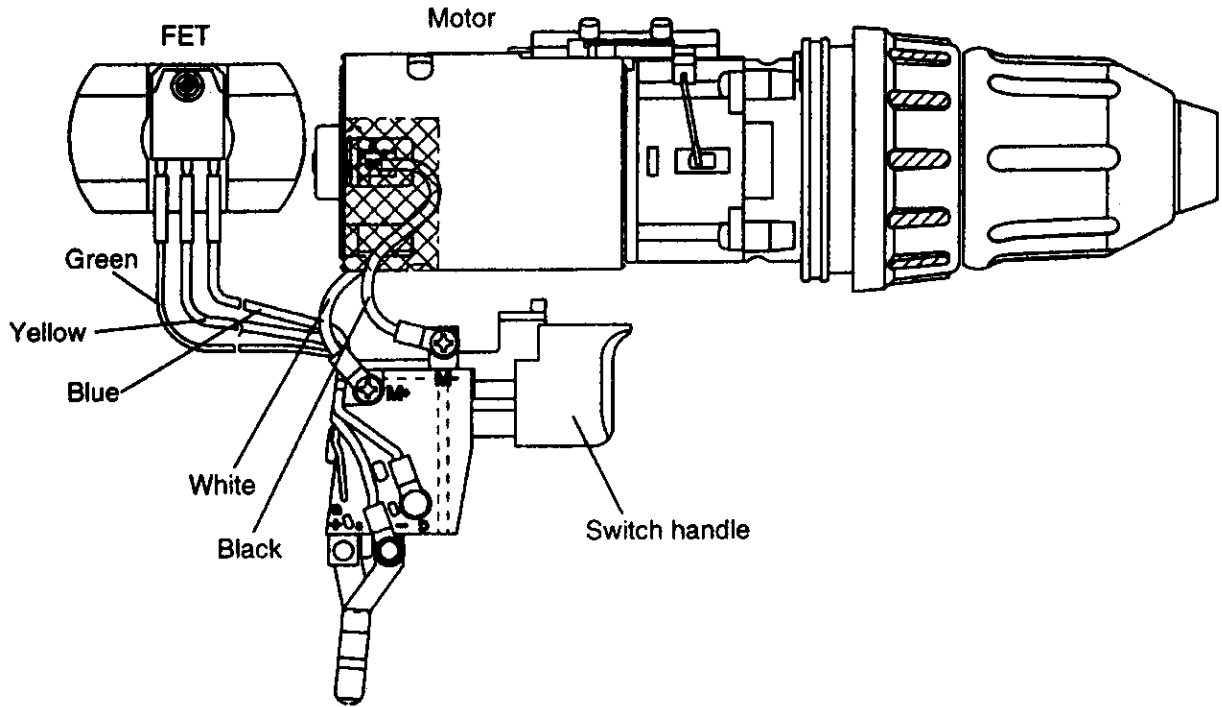

■ EY6431

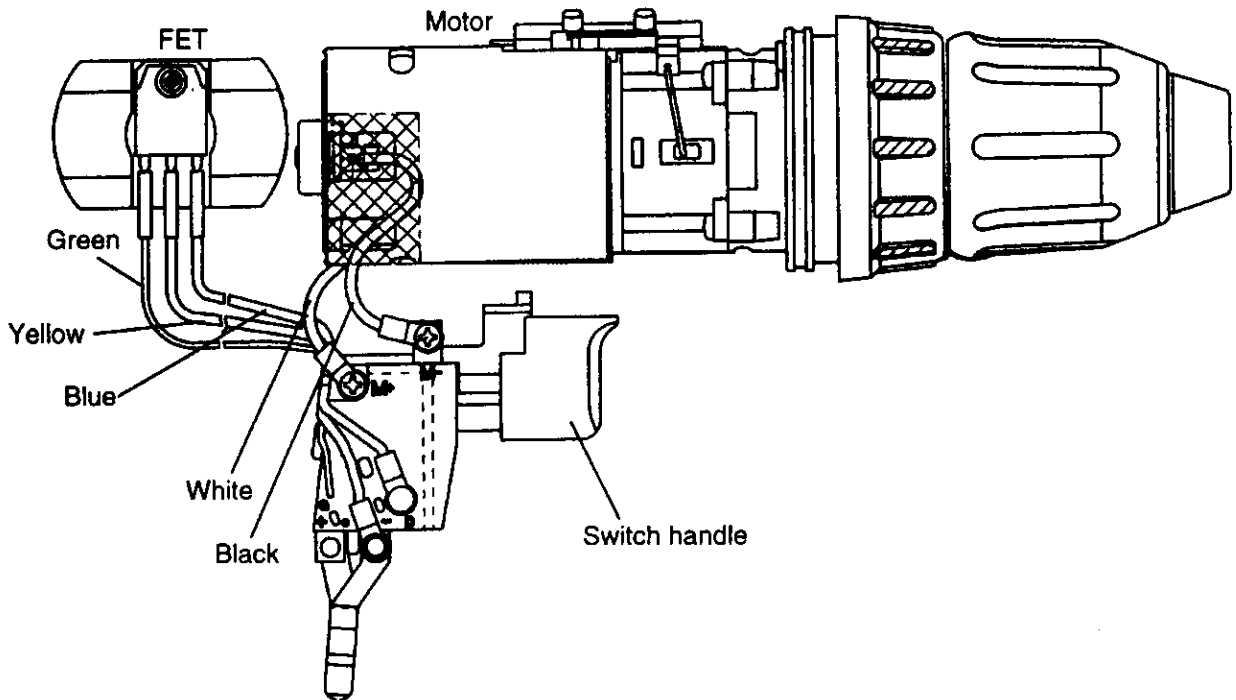

TROUBLESHOOTING GUIDE (Refer to WIRING CONNECTION DIAGRAM)

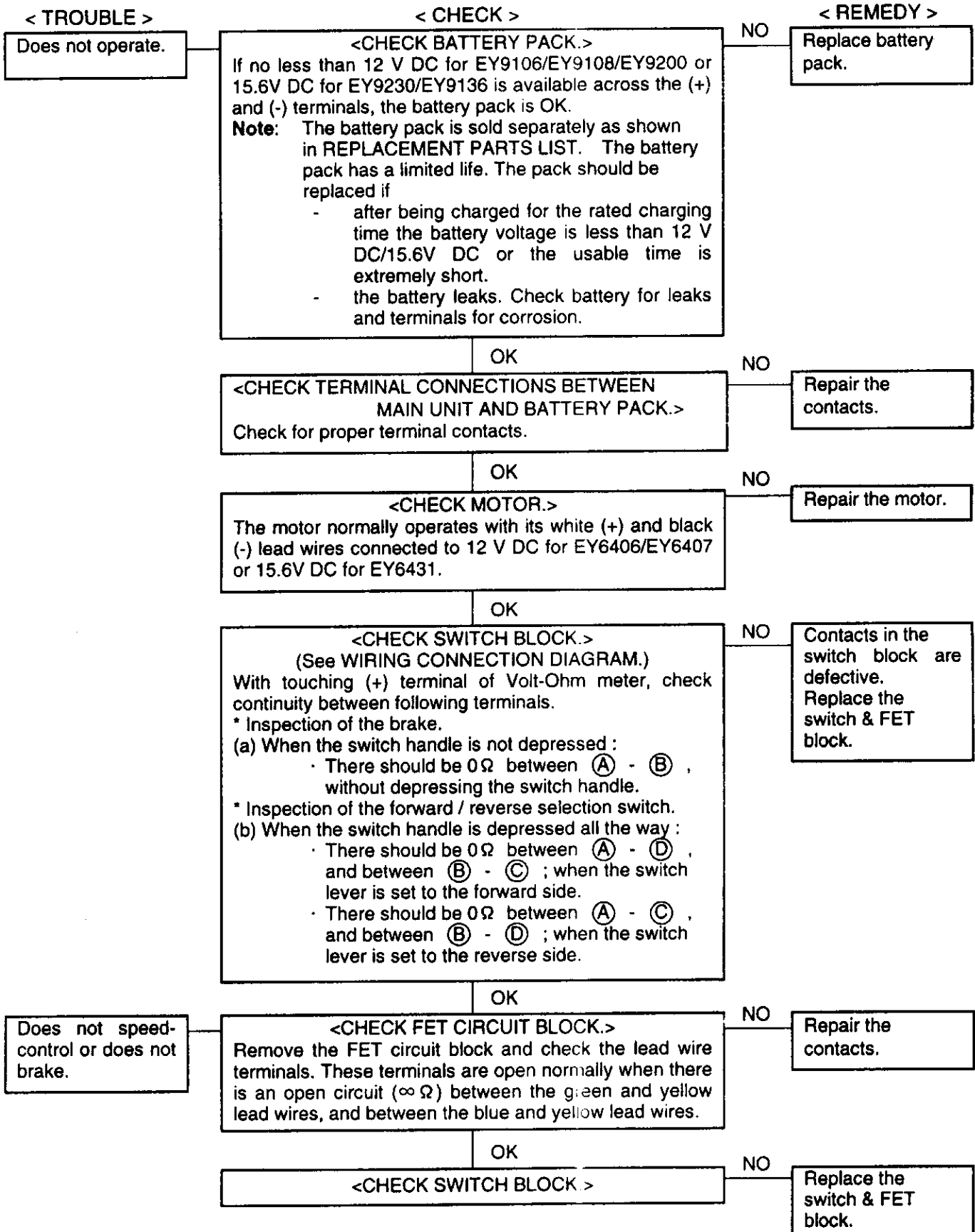

SCHEMATIC DIAGRAM

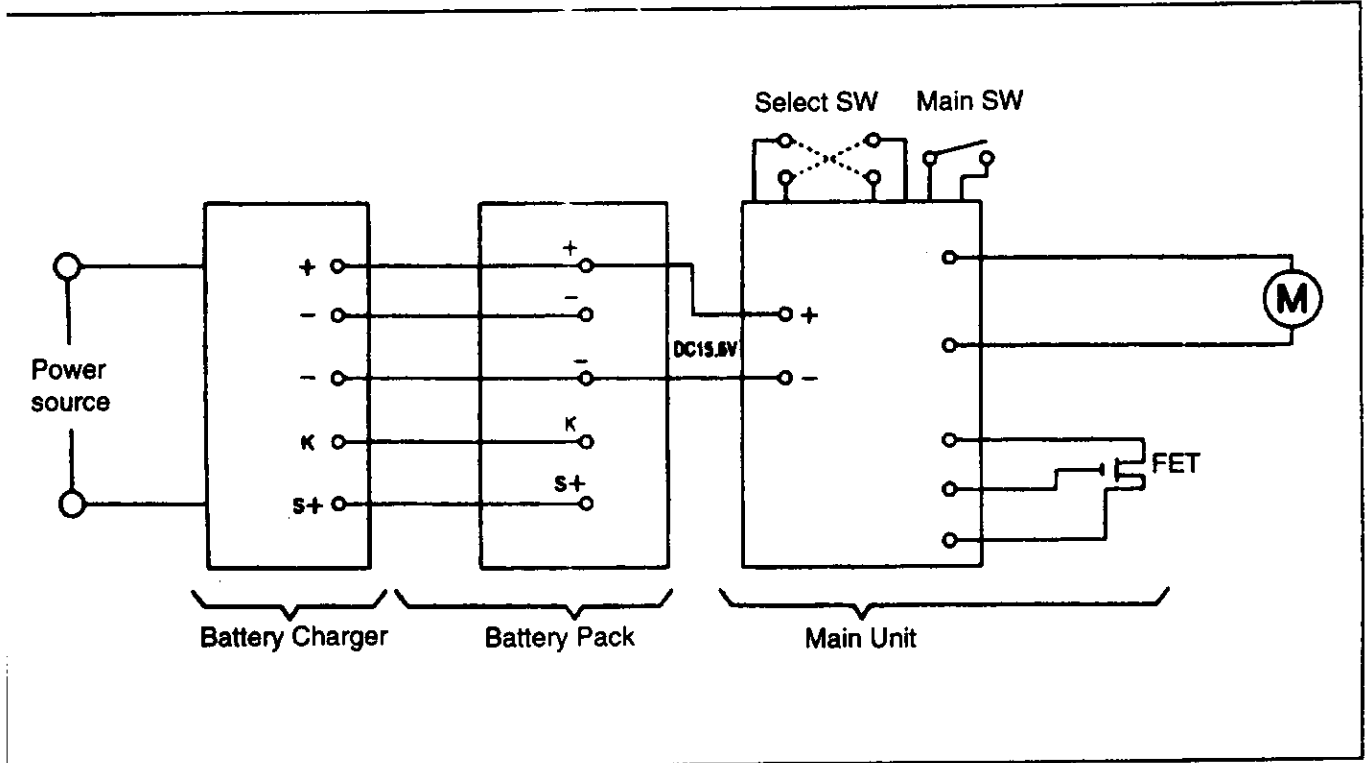

EXPLODED VIEW FOR EY 6406 · EY6407

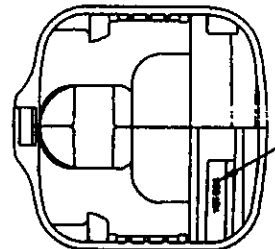
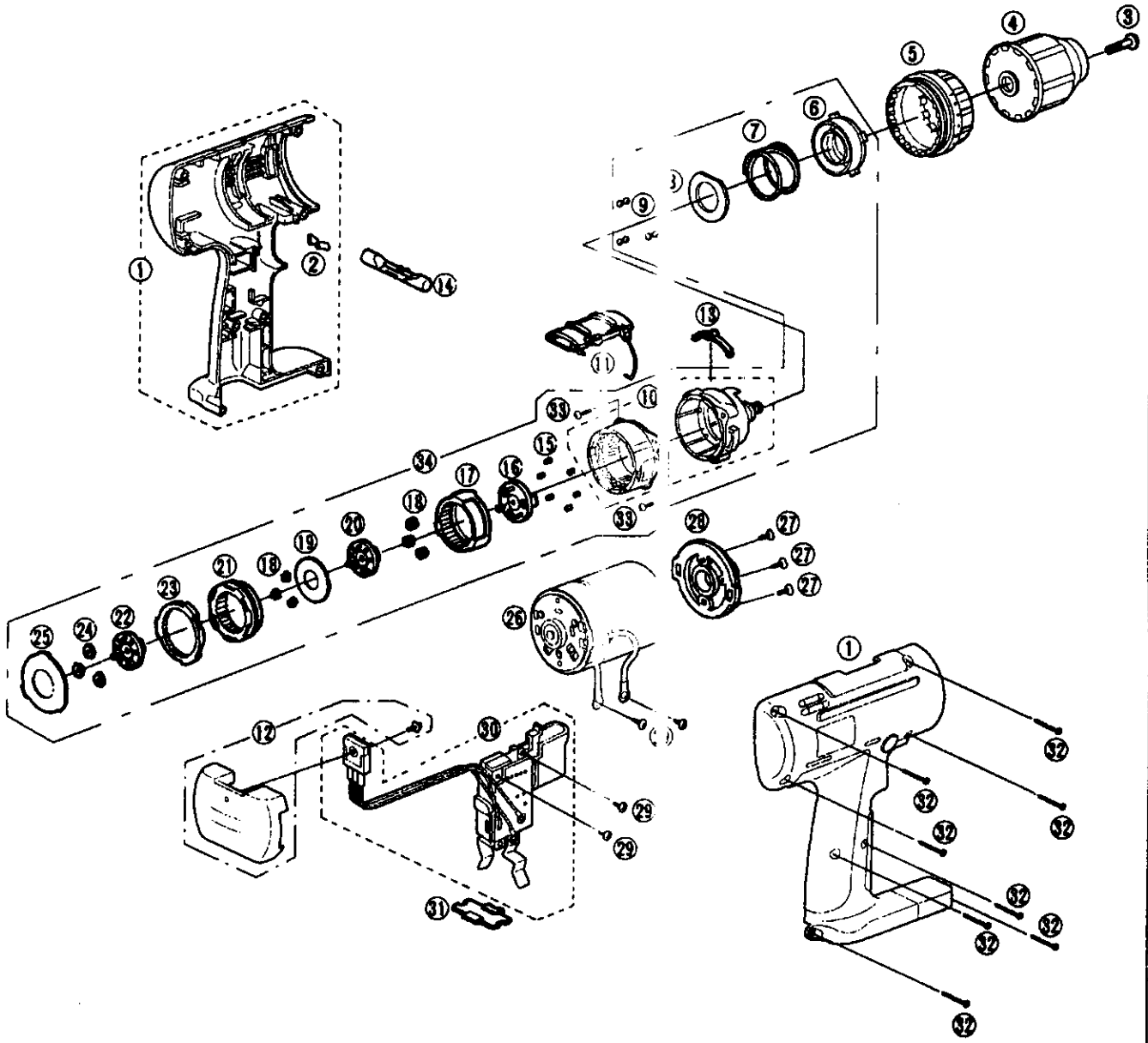

Production marking 6 digits.

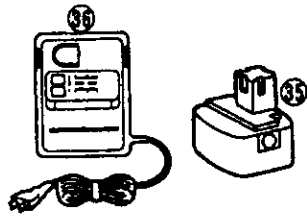

REPLACEMENT PARTS LIST FOR EY6406 · EY6407

NOTE : *A . . . available as an optional accessory

*B . . . only available as set

*C . . . available individually

Ref.No.	Part No. for EY6406	Part No. for EY6407	Part Name & Descriptions	Per unit	Remarks
▲ 1	EY6406K3078	EY6407K3078	HOUSING AB SET	1	
2	EY6481L0177	EY6481L0177	CLICK SPRING	1	
▲ 3	EYT103L6807	EYT103L6807	CHUCK FASTENING SCREW	1	
▲ 4	EY9795	EY9796	KEYLESS CHUCK	1	*A
▲ 5	EY6406Y3228	EY6406Y3228	CLUTCH HANDLE	1	
▲ 6	EY6406L0638	EY6406L0638	ADJUSTING SCREW	1	
▲ 7	EY6406L0168	EY6406L0168	CLUTCH SPRING	1	
▲ 8	EY6406L0578	EY6406L0578	CLUTCH PLATE	1	
9	EY560B6967	EY560B6967	STEEL BALL	12	*B ϕ 5
▲ 10	EY6406L1078	EY6406L1078	DRIVING BLOCK	1	
▲ 11	EY6406Y3238	EY6406Y3238	H/L HANDLE	1	
▲ 12	EY6406L2568	EY6406L2568	HEAT SINK	1	
▲ 13	EY6406L0178	EY6406L0178	CLICK SPRING A	1	
▲ 14	EY6402Y3247	EY6402Y3247	F/R SELECTOR HANDLE	1	
15	EY6283L0377	EY6283L0377	ROLLER PIN	6	*B ϕ 3.175*7.2
▲ 16	EY6406L1118	EY6406L1118	CARRIER	1	
▲ 17	EY6406L1488	EY6406L1488	RING GEAR	1	
▲ 18	EY6406L1348	EY6406L1348	PLANET GEAR	6	*B (3PCS/PK)
▲ 19	EY6406L0858	EY6406L0858	THRUST PLATE	1	
▲ 20	EY6406L1128	EY6406L1128	CARRIER A	1	
▲ 21	EY6406L1468	EY6406L1468	RING GEAR A	1	
▲ 22	EY6406L1108	EY6406L1108	CARRIER B	1	
▲ 23	EY6406L1478	EY6406L1478	RING GEAR B	1	
▲ 24	EY6406L1358	EY6406L1358	PLANET GEAR B	3	*B
▲ 25	EY6406L0888	EY6406L0888	THRUST PLATE	1	
▲ 26	EY6406L1008	EY6406L1008	MOTOR	1	
27	EY6230L6027	EY6230L6027	SCREW	3	*C K3-6
▲ 28	EY6406L0028	EY6406L0028	MOTOR MOUNTING PLATE	1	
29	EY6207Y6027	EY6207Y6027	SCREW	2	*C K3-5
▲ 30	EY6406Y2008	EY6406Y2008	SWITCH BLOCK	1	
31	EY6230L0207	EY6230L0207	DUST PREVENTIVE PLATE	1	
▲ 32	EY6230K9218	EY6230K9218	TAPPING SCREW	8	*C K3-20
▲ 33	EY6406K9038	EY6406K9038	TORX TAPPING SCREW	4	*C K3-12
▲ 34	EY6406L1458	EY6406L1458	GEAR BOX BLOCK	1	
▲ 35	EY9106	EY9200	BATTERY PACK	1	*A
▲ 36	EY0230	EY0230	BATTERY CHARGER	1	*A
▲ -	EY9594	EY9594	TOOL CASE	1	*A
▲ -	EY6406K8108	EY6406K8108	OPERATING INSTRUCTIONS	1	

EXPLODED VIEW FOR EY6431

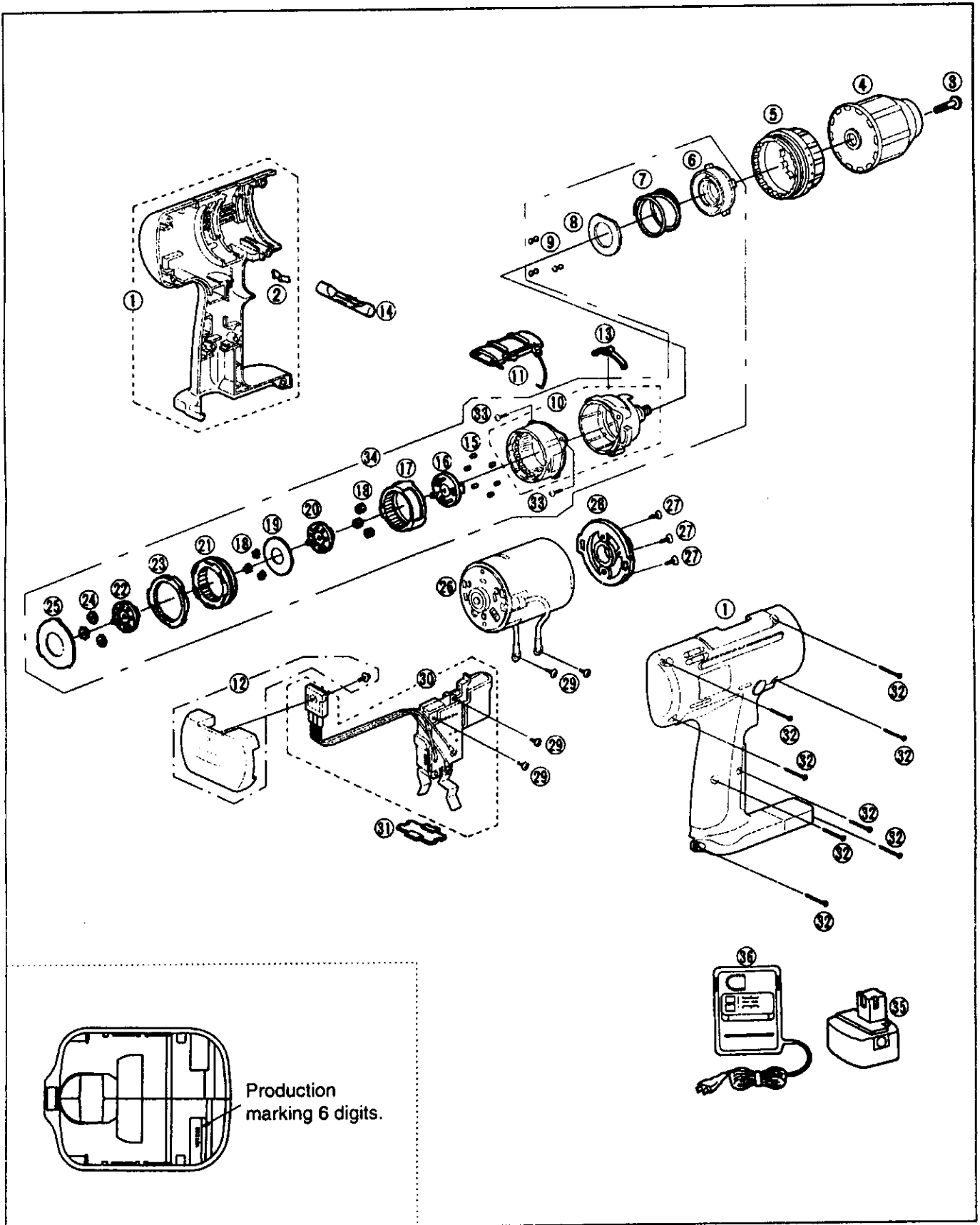

REPLACEMENT PARTS LIST FOR EY6431

NOTE : *A . . . available as an optional accessory

*B . . . only available as set

*C . . . available individually

Ref.No.	Part No.	Part Name & Descriptions	Per unit	Remarks
▲ 1	EY6431K3078	HOUSING AB SET	1	
2	EY6481L0177	CLICK SPRING	1	
▲ 3	EYT103L6807	CHUCK FASTENING SCREW	1	
▲ 4	EY9796	KEYLESS CHUCK	1	*A
▲ 5	EY6406Y3228	CLUTCH HANDLE	1	
▲ 6	EY6406L0638	ADJUSTING SCREW	1	
▲ 7	EY6431L0168	CLUTCH SPRING	1	
▲ 8	EY6406L0578	CLUTCH PLATE	1	
9	EY560B6967	STEEL BALL	12	*B ϕ 5
▲ 10	EY6431L1078	DRIVING BLOCK	1	
▲ 11	EY6406Y3238	H/L HANDLE	1	
▲ 12	EY6406L2568	HEAT SINK	1	
▲ 13	EY6406L0178	CLICK SPRING A	1	
▲ 14	EY6402Y3247	F/R SELECTOR HANDLE	1	
15	EY6283L0377	ROLLER PIN	6	*B ϕ 3.175*7.2
▲ 16	EY6406L1118	CARRIER	1	
▲ 17	EY6406L1488	RING GEAR	1	
▲ 18	EY6406L1348	PLANET GEAR	6	*B (3PCS/PK)
▲ 19	EY6406L0858	THRUST PLATE	1	
▲ 20	EY6406L1128	CARRIER A	1	
▲ 21	EY6406L1468	RING GEAR A	1	
▲ 22	EY6406L1108	CARRIER B	1	
▲ 23	EY6406L1478	RING GEAR B	1	
▲ 24	EY6406L1358	PLANET GEAR B	3	*B
▲ 25	EY6406L0888	THRUST PLATE	1	
▲ 26	EY6431L1008	MOTOR	1	
27	EY6230L6027	SCREW	3	*C K3-6
▲ 28	EY6406L0028	MOTOR MOUNTING PLATE	1	
29	EY6207Y6027	SCREW	2	*C K3-5
▲ 30	EY6431Y2008	SWITCH BLOCK	1	
31	EY6230L0207	DUST PREVENTIVE PLATE	1	
▲ 32	EY6230K9218	TAPPING SCREW	8	*C K3-20
▲ 33	EY6406K9038	TORX TAPPING SCREW	4	*C K3-12
▲ 34	EY6431L1458	GEAR BOX BLOCK	1	
▲ 35	EY9136	BATTERY PACK	1	*A
▲ 35	EY9230	BATTERY PACK	1	*A
▲ 36	EY0230	BATTERY CHARGER	1	*A
▲ -	EY9594	TOOL CASE	1	*A
▲ -	EY6406K8108	OPERATING INSTRUCTIONS	1	