

ELECTRIC TOOL PARTS LIST

MASONRY DRILL
Model DM 20V

2005 · 12 · 15
(E1)

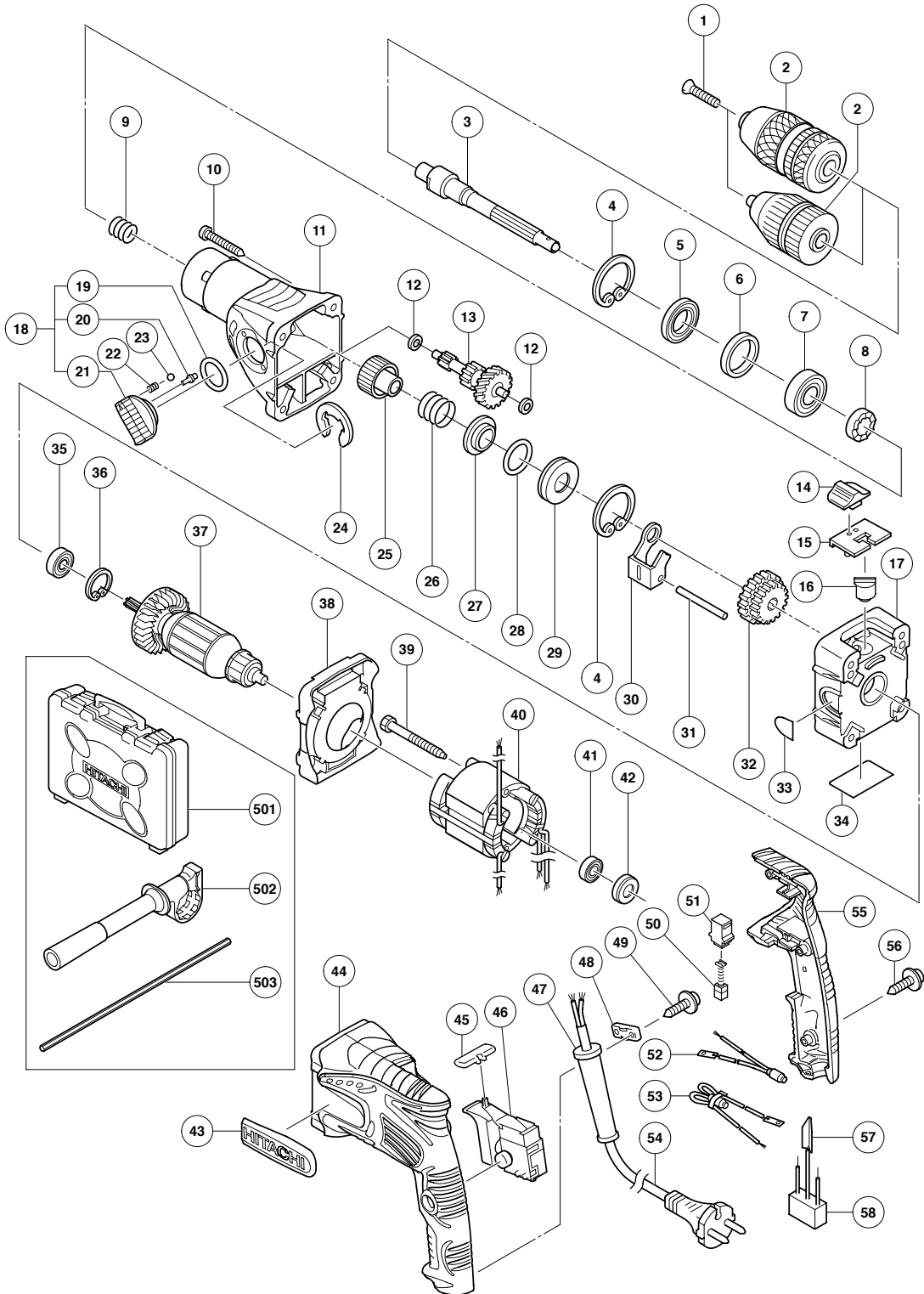

PARTS

DM 20V

ITEM NO.	CODE NO.	DESCRIPTION	NO. USED	REMARKS
* 1	995-344	FLAT HD. SCREW (A) (LEFT HAND) M6X25	1	EXCEPT FOR GBR
* 2	319-546	DRILL CHUCK 13VLRE-N (W/O CHUCK WRENCH)	1	
* 2	316-280	DRILL CHUCK 13VLN (W/O CHUCK WRENCH)	1	FOR GBR
3	325-319	SPINDLE	1	
4	939-556	RETAINING RING FOR D35 HOLE (10 PCS.)	2	
5	971-745	OIL SEAL (A)	1	
6	325-335	DISTANCE RING	1	
7	620-2DD	BALL BEARING 6202DDCMPS2L	1	
8	325-330	RATCHET (A)	1	
9	984-101	SPRING (A)	1	
10	325-336	TAPPING SCREW D5X55	4	
11	325-326	GEAR COVER	1	
12	322-852	WASHER (B)	2	
* 13	325-339	SECOND PINION AND GEAR SET	1	
* 13	325-340	SECOND PINION AND GEAR SET	1	FOR SLIP CLUTCH
14	325-323	CHANGE LEVER	1	
15	325-324	CHANGE COVER	1	
16	325-322	CHANGE SHAFT	1	
17	325-320	INNER COVER	1	
18	322-847	SHIFT LEVER ASS'Y	1	INCLUD. 19-21
19	306-353	O-RING (S-22)	1	
20	322-848	SHIFT PIN	1	
21		SHIFT LEVER	1	
22	981-328	SPRING (H)	1	
23	319-535	STEEL BALL D3.5 (10 PCS.)	1	
24	323-048	RETAINING RING (E-TYPE) FOR D15 SHAFT	1	
25	325-331	RATCHET (B)	1	
26	325-332	SPRING	1	
27	325-333	SLEEVE (A)	1	
28	884-909	O-RING	1	
29	325-334	SLEEVE (B)	1	
30	322-849	SHIFT ARM	1	
31	325-321	PIN D5X68	1	
32	325-327	GEAR	1	
33		HITACHI LABEL	1	
34		NAME PLATE	1	
35	608-DDM	BALL BEARING 608DDC2PS2L	1	
36	939-553	RETAINING RING FOR D22 HOLE (10 PCS.)	1	
* 37	360-652C	ARMATURE 110V	1	
* 37	360-652E	ARMATURE 230V	1	
38	325-325	FAN GUIDE	1	
39	961-672	HEX. HD. TAPPING SCREW D4X50	2	
* 40	340-650C	STATOR 110V	1	
* 40	340-650E	STATOR 230V	1	
41	698-T1X	BALL BEARING 698T1XZZ1MC2E NS7L	1	
42	309-929	RUBBER BUSHING	1	
43	325-338	HITACHI PLATE	1	
44	324-553	HOUSING	1	
45	322-853	PUSHING BUTTON	1	
46	325-337	SWITCH (1P PILLAR TYPE)	1	
47	953-327	CORD ARMOR D8.8	1	

